

Vanguard™ 6.5 Gross HP 205 CC

Bore 2.68 in. (68.28 mm)
Stroke 2.20 in. (55.88 mm)
Oil Capacity 20-22 fl. oz. (0.59-0.65 L)



Features:

- Dura-Bore™ cast iron cylinder sleeve for extended life
- Float carburetor for consistent easy starting
- Maintenance-free Magnetron® electronic ignition for quick, dependable starts
- Dual-Clean™ air cleaner pleated paper filter with a foam pre-cleaner ensures maximum protection for extended engine life
- Oil Gard low oil engine shutdown device
- Overhead valve design (OHV) for cooler operation and longer valve life
- Buyer protection package provides three-year commercial limited warranty

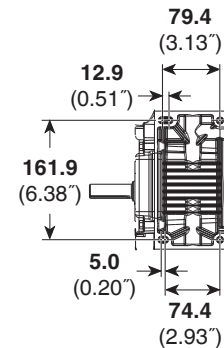
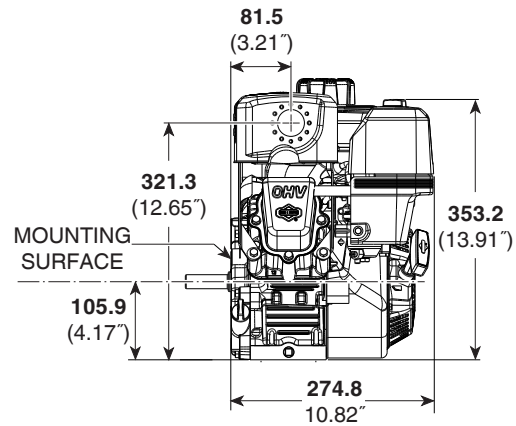
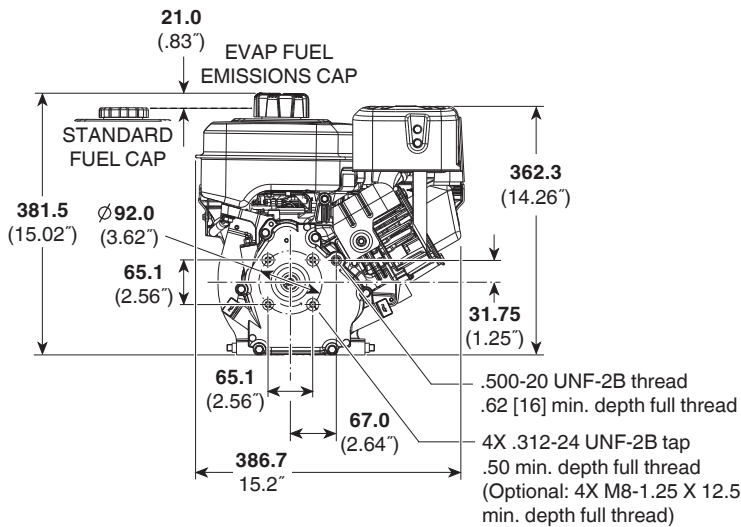

Model Type	Shipping Weight	Crankshaft	Crankshaft (P.T.O.) Extension	Dimension	Starter Position Bolt-On/Changeable	Oil Filler & Drain	Governor	Controls	Manual Choke	Fuel Tank (Quarts)	Transport Guard™, Fuel/Ignition shut-off	Oil Gard	Flange Mitg.	Top Governor Speed	Notes
13H332															
0036	48	798532	3/4" dia., Keyway, tapped 5/16-24	2-27/64(c)	10.30	D	M	AG/MF	X	3.3	X	X	X	3600	•

• Ball bearing PTO and magneto side