

Bore: 3.56 in. (90.4 mm) Stroke: 3.06 in. (77.7 mm) Displacement: 30.59 cu. in. (501 cc) Dry Weight: 74 lbs. (33.6 kg)

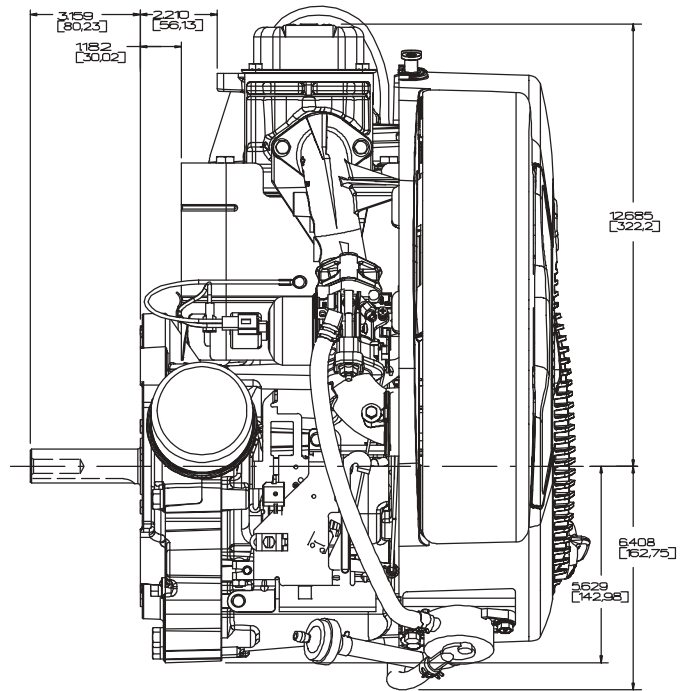

696232

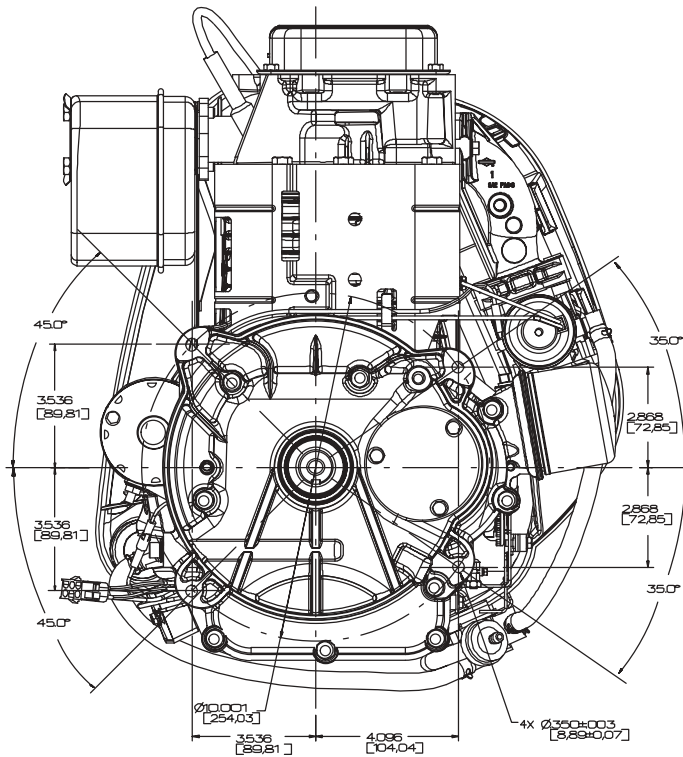
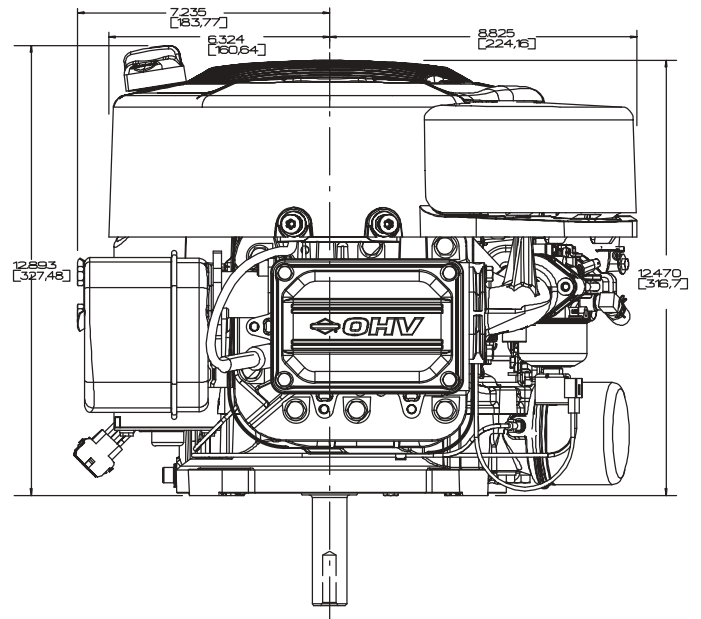
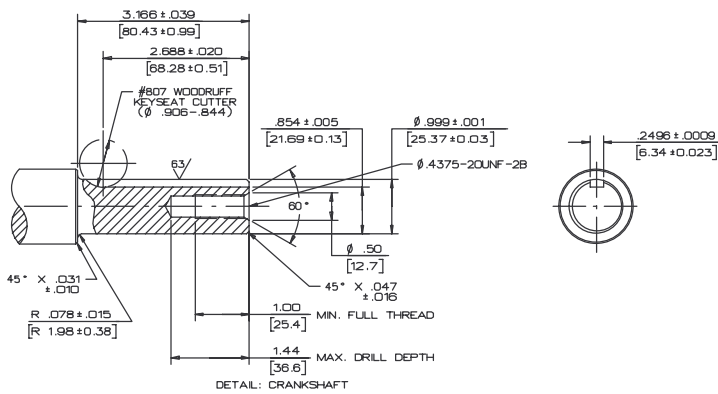

17.5 HP

31L700 ELS™ Series

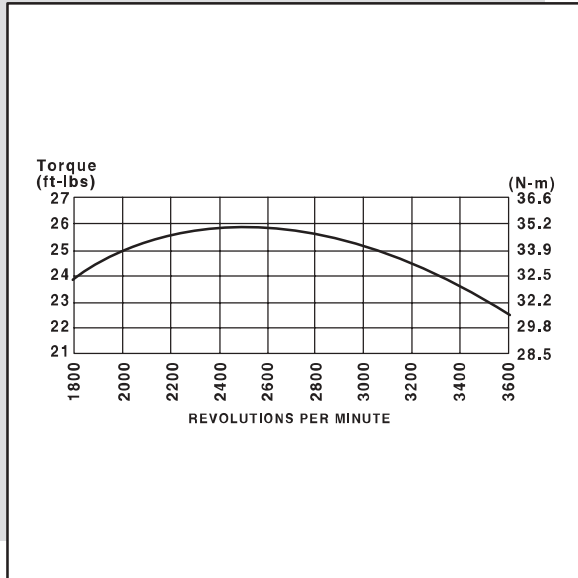

MODEL	17.5 HP 500 CC 31L777-0169-E1	17.5 HP 500 CC 31L777-0122-E1	17.5 HP 500 CC 31L777-0036-E1
CYLINDER	ALUMINUM W/ C.I. SLEEVE	ALUMINUM W/ C.I. SLEEVE	ALUMINUM W/ C.I. SLEEVE
FLYWHEEL	HEAVY	HEAVY	HEAVY
STARTER	ROTATING SCREEN REGULAR STARTER 12V DUAL CIRCUIT ALTERNATOR	ROTATING SCREEN REGULAR STARTER 12V 16 AMP ALTERNATOR	ROTATING SCREEN REGULAR STARTER 12V 9 AMP ALTERNATOR
SPECIAL FEATURES	EXTND LIFE PISTON/RINGS OVERHEAD VALVE ANTI-VIBRATION SYS WHISPER COOL FAN	EXTND LIFE PISTON/RINGS OVERHEAD VALVE ANTI-VIBRATION SYS WHISPER COOL FAN	EXTND LIFE PISTON/RINGS OVERHEAD VALVE ANTI-VIBRATION SYS WHISPER COOL FAN
CRANKSHAFT	696232-1" STRAIGHT, 1/4 KWY 7/16-20 D&T	696232-1" STRAIGHT, 1/4 KWY 7/16-20 D&T	696232-1" STRAIGHT, 1/4 KWY 7/16-20 D&T
BEARINGS	PLAIN PTO DU MAG	PLAIN PTO DU MAG	PLAIN PTO DU MAG
OIL FILL	OPPOSITE CARB SIDE	OPPOSITE CARB SIDE	OPPOSITE CARB SIDE
DIPSTICK	OPP CARB SIDE, EXTENDED	OPP CARB SIDE, EXTENDED	OPP CARB SIDE, EXTENDED
OIL DRAIN	OPPOSITE CARB SIDE	OPPOSITE CARB SIDE	OPPOSITE CARB SIDE
LUBRICATION SYSTEM	EQUIP FOR PRESS SWITCH FULL PRESS LUBE PREMIUM OIL FILTER	PRESS SWITCH INSTALL FULL PRESS LUBE PREMIUM OIL FILTER	EQUIP FOR PRESS SWITCH FULL PRESS LUBE PREMIUM OIL FILTER
FUEL SYSTEM	WITHOUT FUEL TANK 150 MICR FLT 3.5 INCH LINE	WITHOUT FUEL TANK FUEL PUMP INSTALL 60 MIC FILTR 3.5 INCH LINE	WITHOUT FUEL TANK FUEL PUMP INSTALL 150 MICR FLT 3.5 INCH LINE
GOVERNOR	MECHANICAL	MECHANICAL	MECHANICAL
CONTROLS	EQUIP FOR REMOTE	EQUIP FOR REMOTE	EQUIP FOR REMOTE
CHOKE	CHOKE-A-MATIC®	CHOKE-A-MATIC®	CHOKE-A-MATIC®
NO-LOAD TEST SPEED	3300 ± 100 RPM	3600 ± 100 RPM	3300 ± 100 RPM
CASING CLAMP & SCREW	WITHOUT	OPPOSITE CYL HEAD	OPPOSITE CYL HEAD
STOPS	GROUND WIRE TERMINAL W/ DOUBLE LEAD	GROUND WIRE TERMINAL W/ DOUBLE LEAD	GROUND WIRE TERMINAL W/ DOUBLE LEAD
AIR CLEANER	SINGLE PREMIUM WASHABLE INSTALL	SINGLE PREMIUM WASHABLE INSTALL	SINGLE PREMIUM WASHABLE INSTALL
MUFFLER	WITHOUT	PREMIUM QUIET INSTALL	PREMIUM QUIET INSTALL
DEFLECTOR	WITHOUT	SIDE OUT LOOSE	SIDE OUT LOOSE
PAINT	290 SATIN BLACK	290 SATIN BLACK	290 SATIN BLACK
MINIMUM ORDER QTY	12	12	12
PACKAGING	012/024	012/024	012/024



* Indicates that engine specification is included in the *Engine Sales Replacement Specifications*, MS-5568.