

Bore: 3.44 in. (87.4 mm) Stroke: 2.27 in. (57.7 mm) Displacement: 21.0 cu. in. (344.1 cc) Dry Weight: 64 lbs. (29.0 kg)

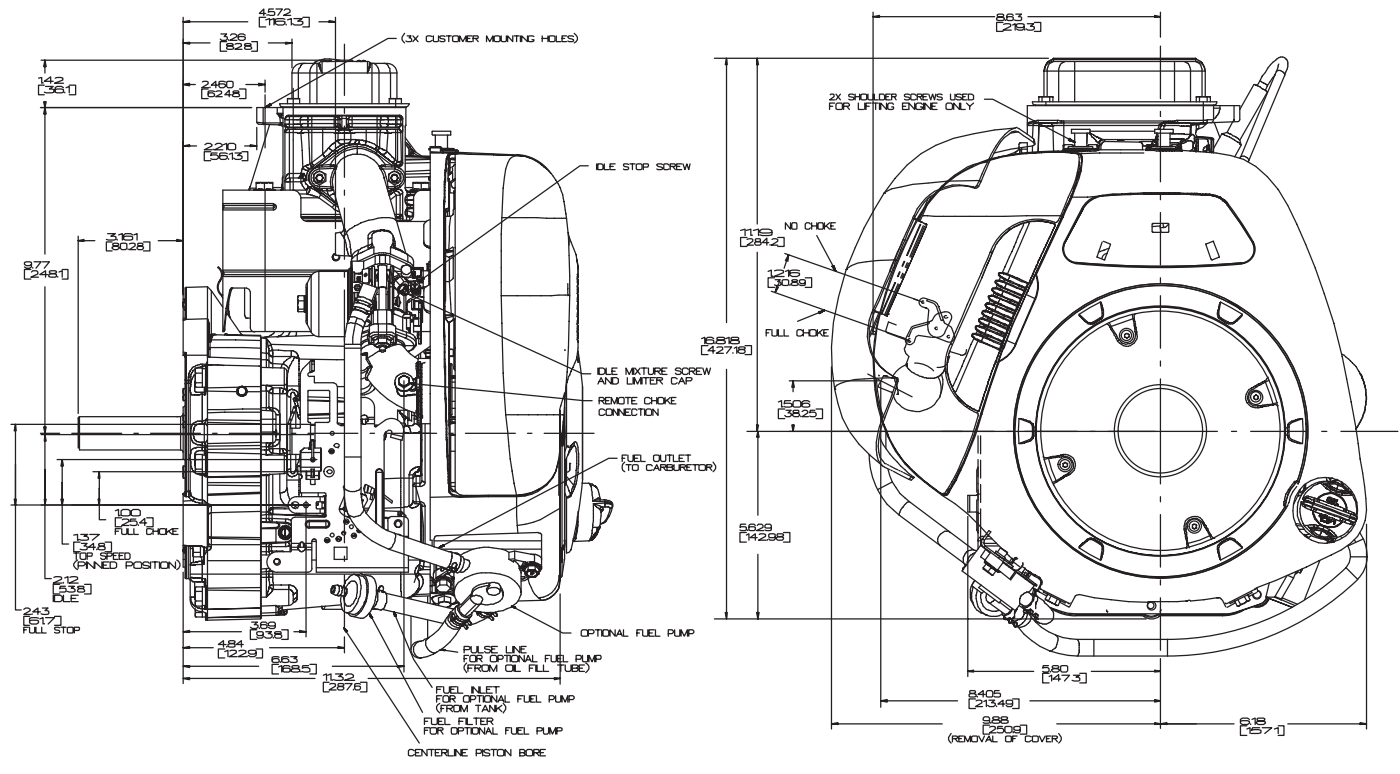

Intek™ V/S Engines

11 HP

216900 INTEK™ Series

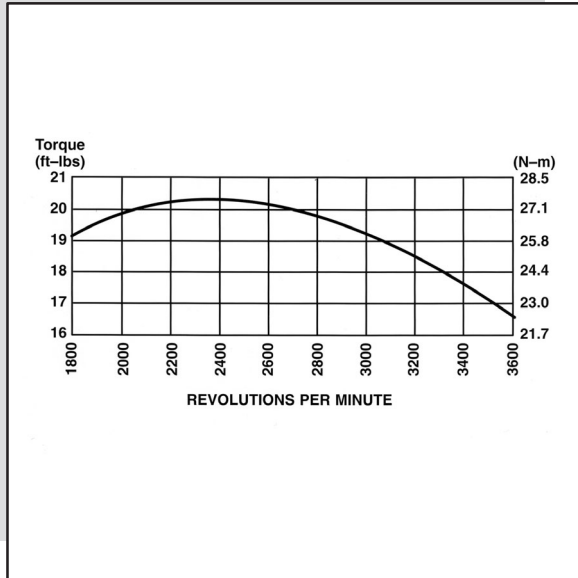

MODEL	11.0 HP 344 CC 216977-0115-E1	11.0 HP 344 CC 216902-0015-E1	11.0 HP 344 CC 216977-0101-E1	11.0 HP 344 CC 216907-0025-E1
CYLINDER	ALUMINUM W/ C.I. SLEEVE	ALUMINUM W/ C.I. SLEEVE	ALUMINUM W/ C.I. SLEEVE	ALUMINUM W/ C.I. SLEEVE
FLYWHEEL	HEAVY	HEAVY	HEAVY	HEAVY
STARTER	9:00 REWIND REGULAR STARTER 12V 16 AMP ALTERNATOR 393422-WIRE HARNESS	9:00 REWIND REGULAR STARTER 12V	ROTATING SCREEN REGULAR STARTER 12V DUAL CIRCUIT ALTERNATOR	ROTATING SCREEN REGULAR STARTER 12V DUAL CIRCUIT ALTERNATOR
PTO MOUNTING	FLANGE MOUNT	FLANGE MOUNT	FLANGE MOUNT	FLANGE MOUNT
CRANKSHAFT	695898-1" DIA 1/4" KWY 7/16-20 D&T	695898-1" DIA 1/4" KWY 7/16-20 D&T	695898-1" DIA 1/4" KWY 7/16-20 D&T	695898-1" DIA 1/4" KWY 7/16-20 D&T
BEARINGS	PLAIN PTO DU MAG	PLAIN PTO DU MAG	PLAIN PTO DU MAG	PLAIN PTO DU MAG
OIL FILL	OPPOSITE CARB SIDE	OPPOSITE CARB SIDE	OPPOSITE CARB SIDE	OPPOSITE CARB SIDE
DIPSTICK	OPP CARB SIDE, EXTENDED	OPP CARB SIDE, EXTENDED	OPP CARB SIDE, EXTENDED	OPP CARB SIDE, EXTENDED
OIL DRAIN	OPPOSITE CARB SIDE	OPPOSITE CARB SIDE	OPPOSITE CARB SIDE	OPPOSITE CARB SIDE
LUBRICATION SYSTEM	OIL PUMP INSTALL OIL FILTER INSTALL PRESSURE SWITCH INSTALL	OIL PUMP INSTALL OIL FILTER INSTALL PRESSURE SWITCH INSTALL	OIL PUMP INSTALL OIL FILTER INSTALL PRESSURE SWITCH INSTALL	OIL PUMP INSTALL OIL FILTER INSTALL PRESSURE SWITCH INSTALL
FUEL SYSTEM	WITHOUT FUEL TANK FUEL PUMP INSTALL 150 MICR FLT 3.5 INCH HOSE	WITHOUT FUEL TANK FUEL PUMP INSTALL 150 MICR FLT 3.5 INCH LINE	WITHOUT FUEL TANK 150 MICR FLT 3.5 INCH LINE	WITHOUT FUEL TANK 150 MICR FLT 3.5 INCH LINE
GOVERNER	MECHANICAL	MECHANICAL	MECHANICAL	MECHANICAL
CONTROLS	EQUIP FOR REMOTE	EQUIP FOR REMOTE	EQUIP FOR REMOTE	EQUIP FOR REMOTE
CHOKE	CHOKE-A-MATIC	CHOKE-A-MATIC	CHOKE-A-MATIC	CHOKE-A-MATIC
NO-LOAD TEST SPEED	3600 ± 100 RPM	3400 ± 100 RPM	3300 ± 100 RPM	3600 ± 100 RPM
CASING CLAMP & SCREW	OPPOSITE CYL HEAD	OPPOSITE CYL HEAD	OPPOSITE CYL HEAD	OPPOSITE CYL HEAD
STOPS	GROUND WIRE TERMINAL W/ SINGLE LEAD	GROUND WIRE TERMINAL W/ SINGLE LEAD	GROUND WIRE TERMINAL W/ SINGLE LEAD	GROUND WIRE TERMINAL W/ SINGLE LEAD
AIR CLEANER	INSTALLED DUAL ELEMENT	INSTALLED DUAL ELEMENT	INSTALLED DUAL ELEMENT	INSTALLED DUAL ELEMENT
MUFFLER	PERFORMANCE QUIET INSTALL	SQ. LO-TONE INSTALL	WITHOUT	SQ. LO-TONE INSTALL
DEFLECTOR	SIDE OUT LOOSE	SIDE OUT LOOSE	WITHOUT	SIDE OUT LOOSE
PAINT	290 SATIN BLACK	290 SATIN BLACK	290 SATIN BLACK	290 SATIN BLACK
MINIMUM ORDER QTY	12	12	12	12
PACKAGING	012/024	012/024	012/024	012/024

Intek™ V/S
Engines

* Indicates that engine specification is included in the *Engine Sales Replacement Specifications and Price List*, MS-5568.