



VANGUARD™

V-TWIN SERIES

Outline Drawings

16 HP 303400

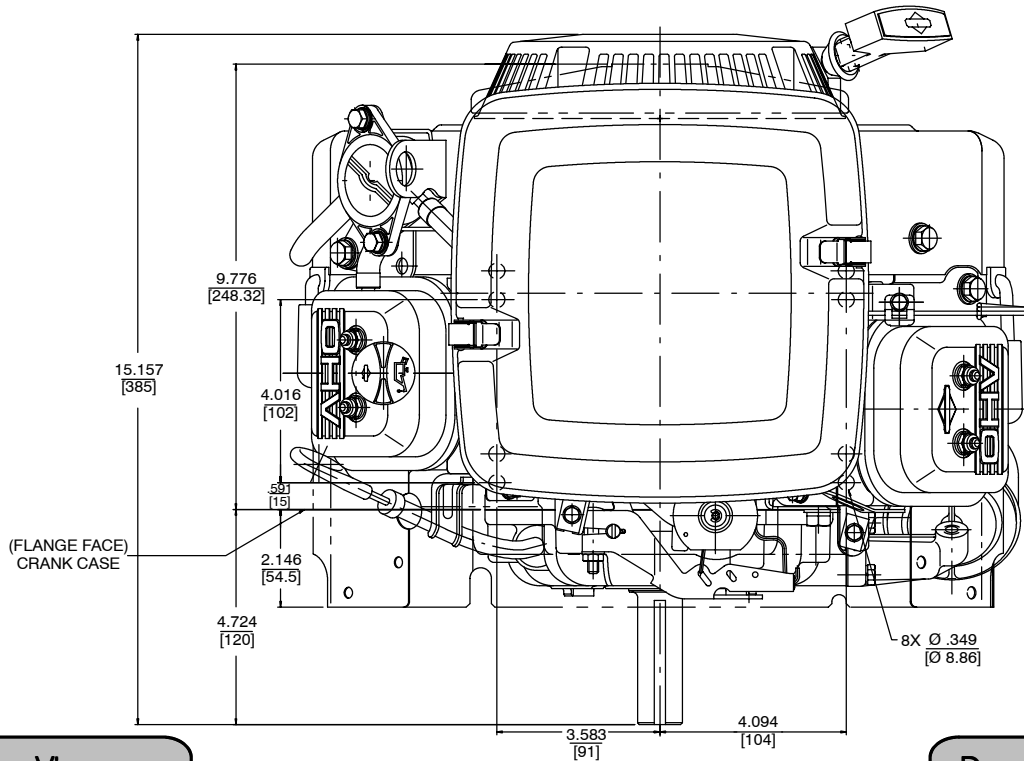

Top View

Dwg 2904000006

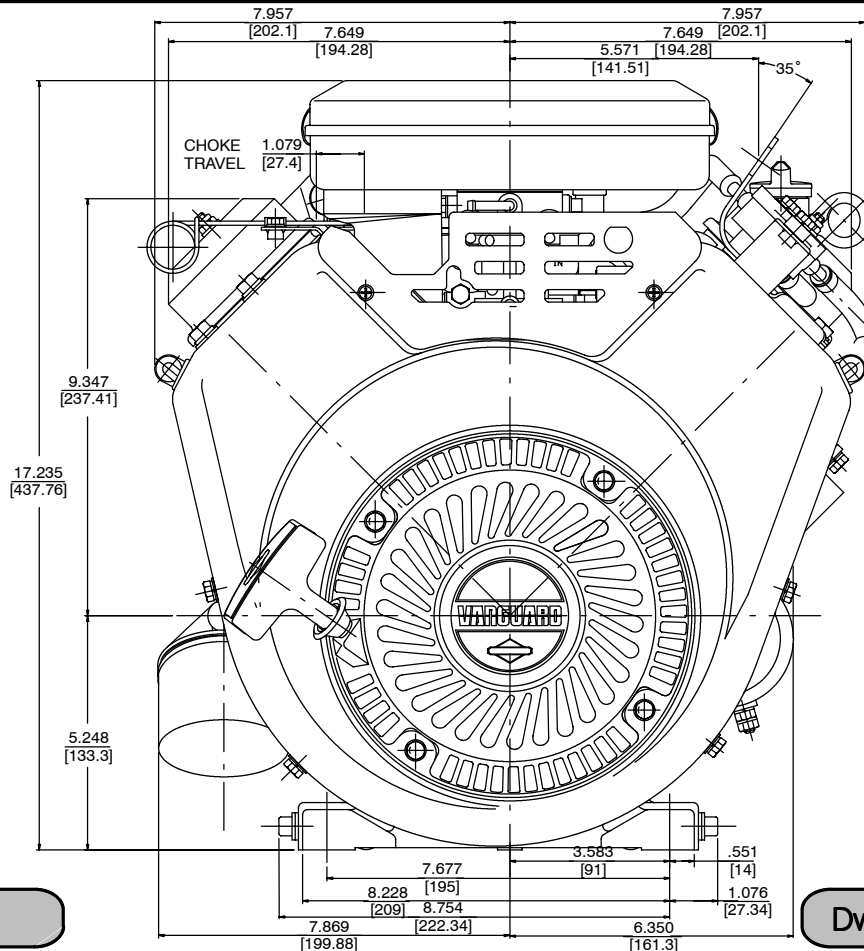

Front View

Dwg 2904000006

BRIGGS & STRATTON

VANGUARD™ V-TWIN SERIES

16 HP 303400

Outline Drawings

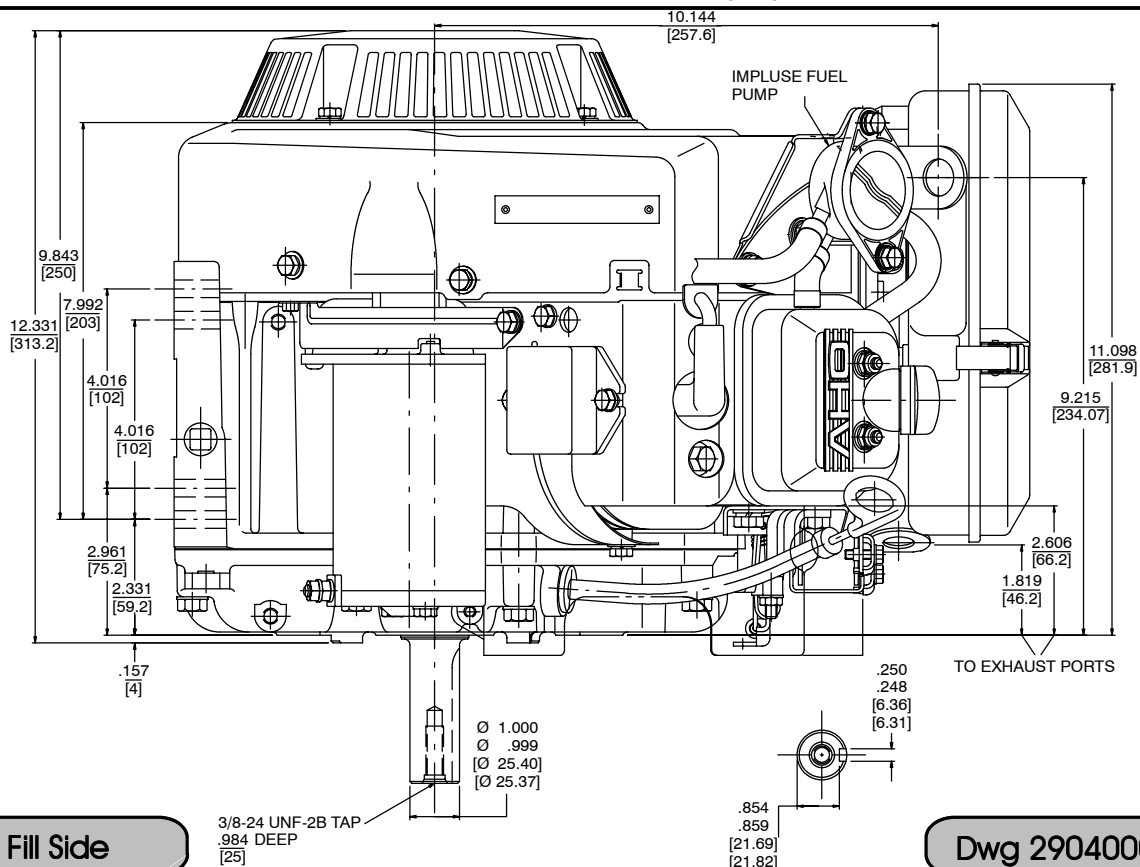
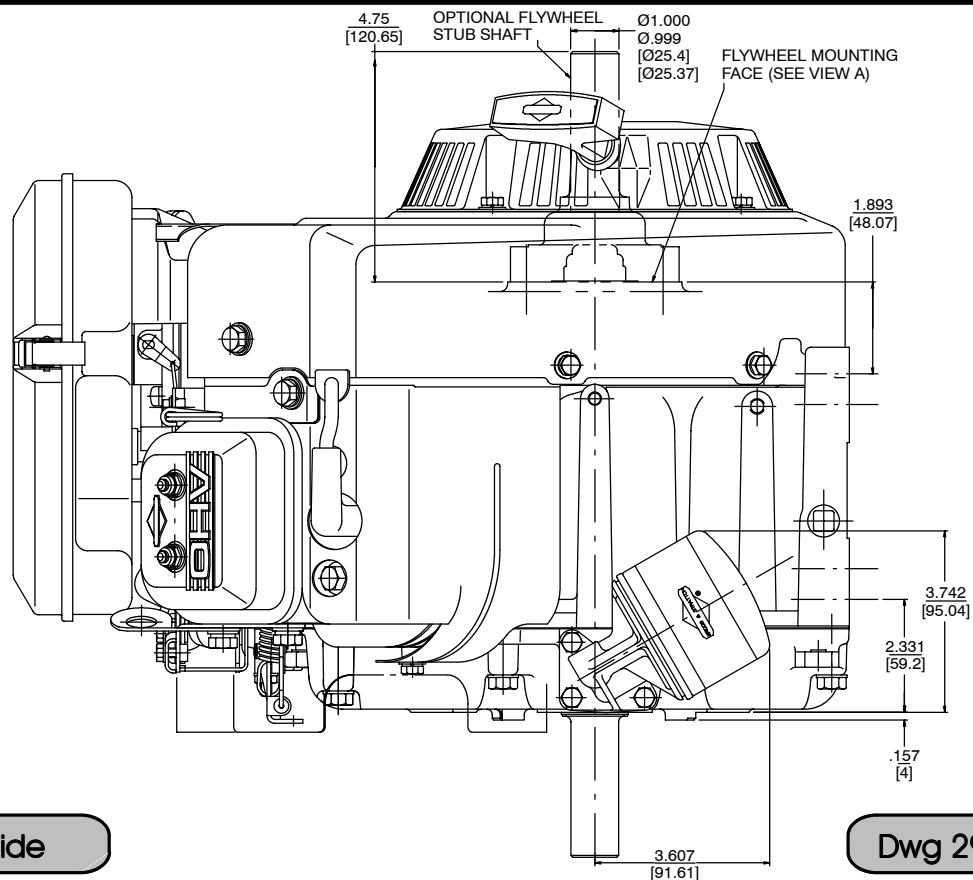



VANGUARD™

V-TWIN SERIES

Outline Drawings

16 HP 303400

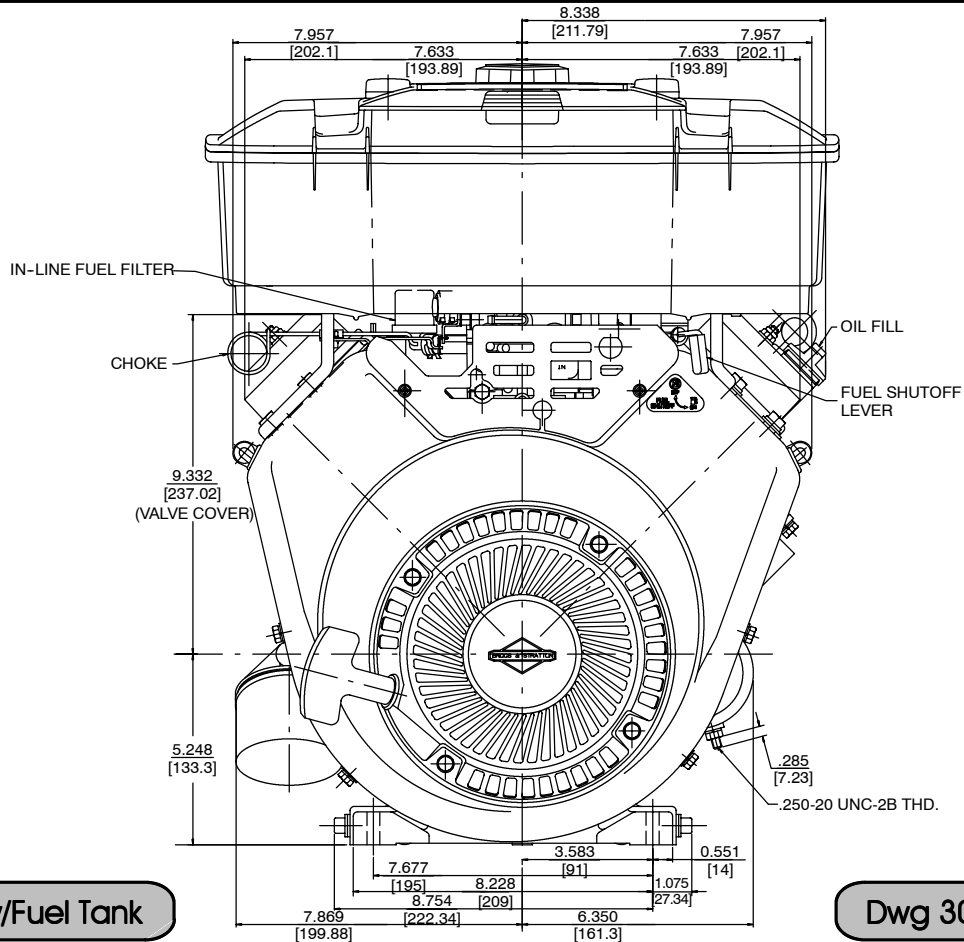
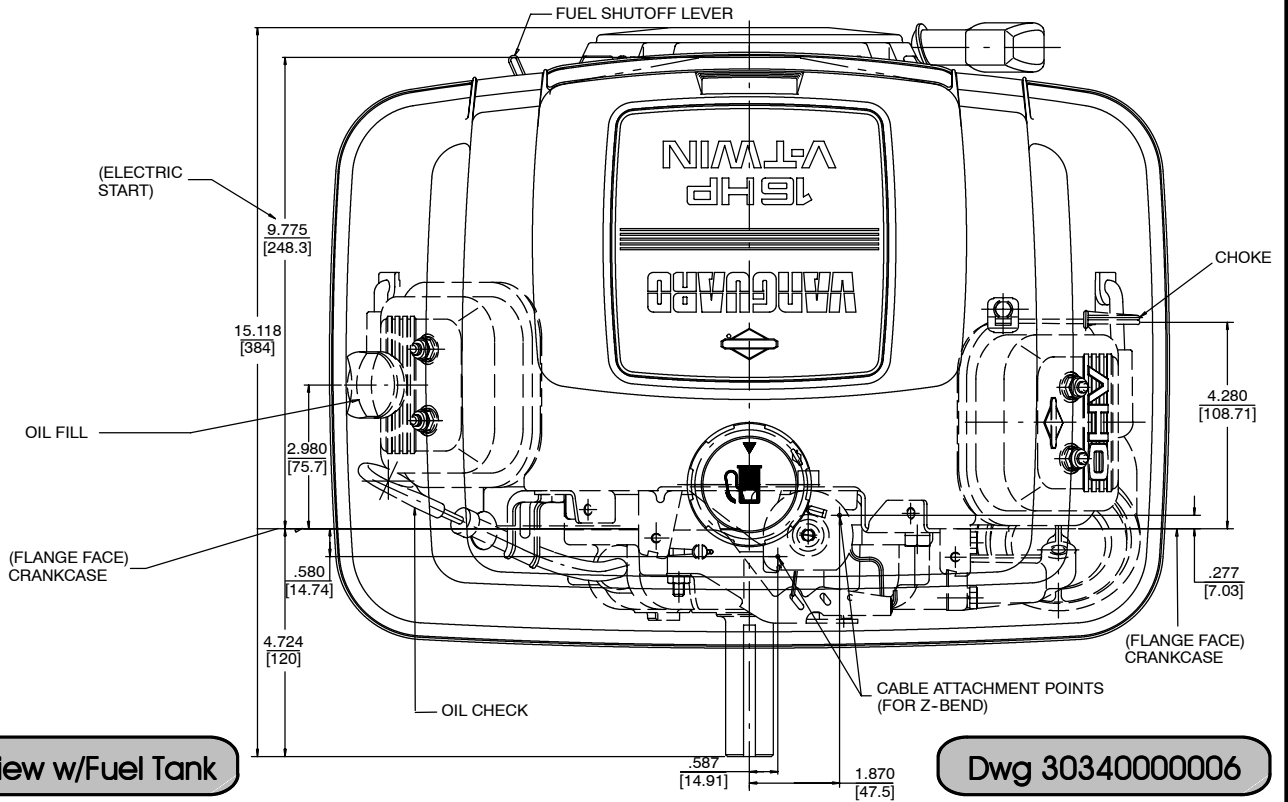

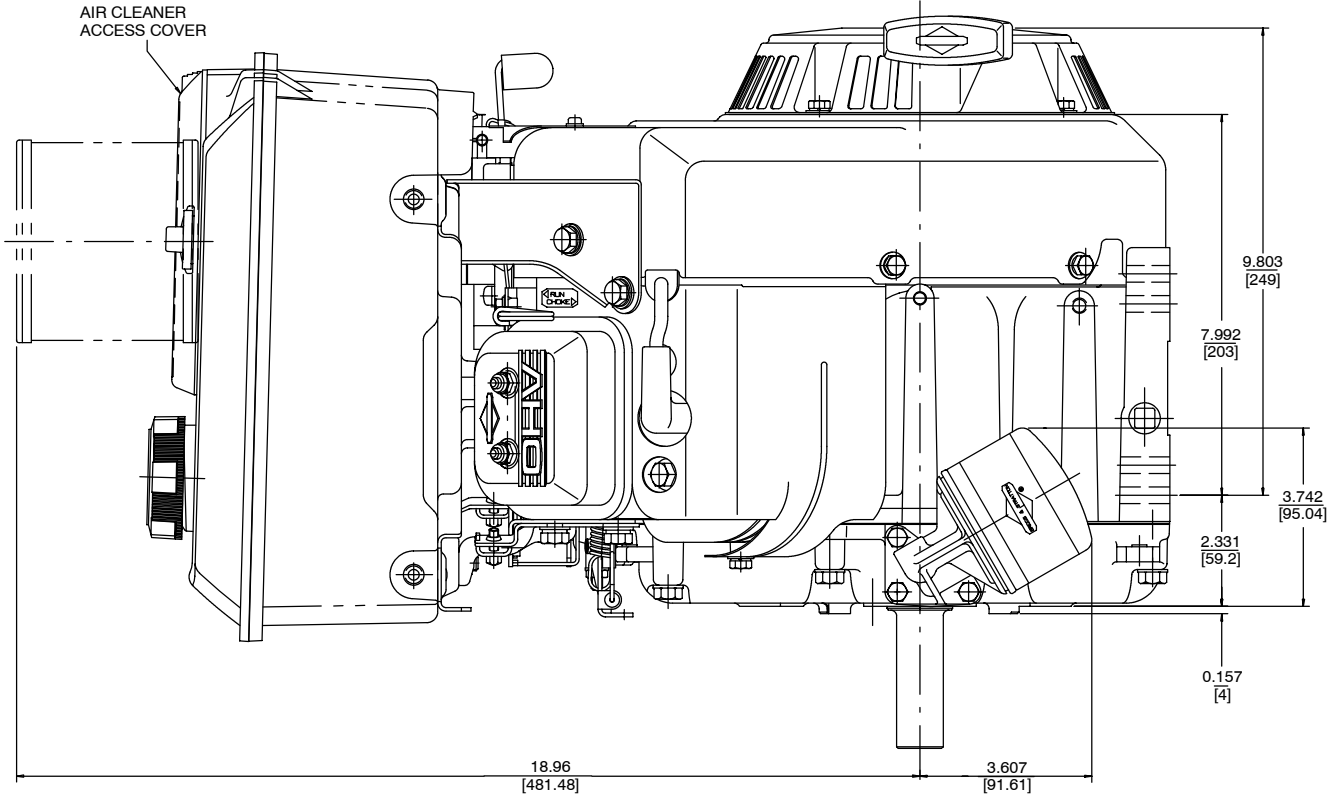

Oil Filter Side w/Fuel Tank

(FOR REMOVAL OF AIR CLEANER CARTRIDGE)

Dwg 3034000006

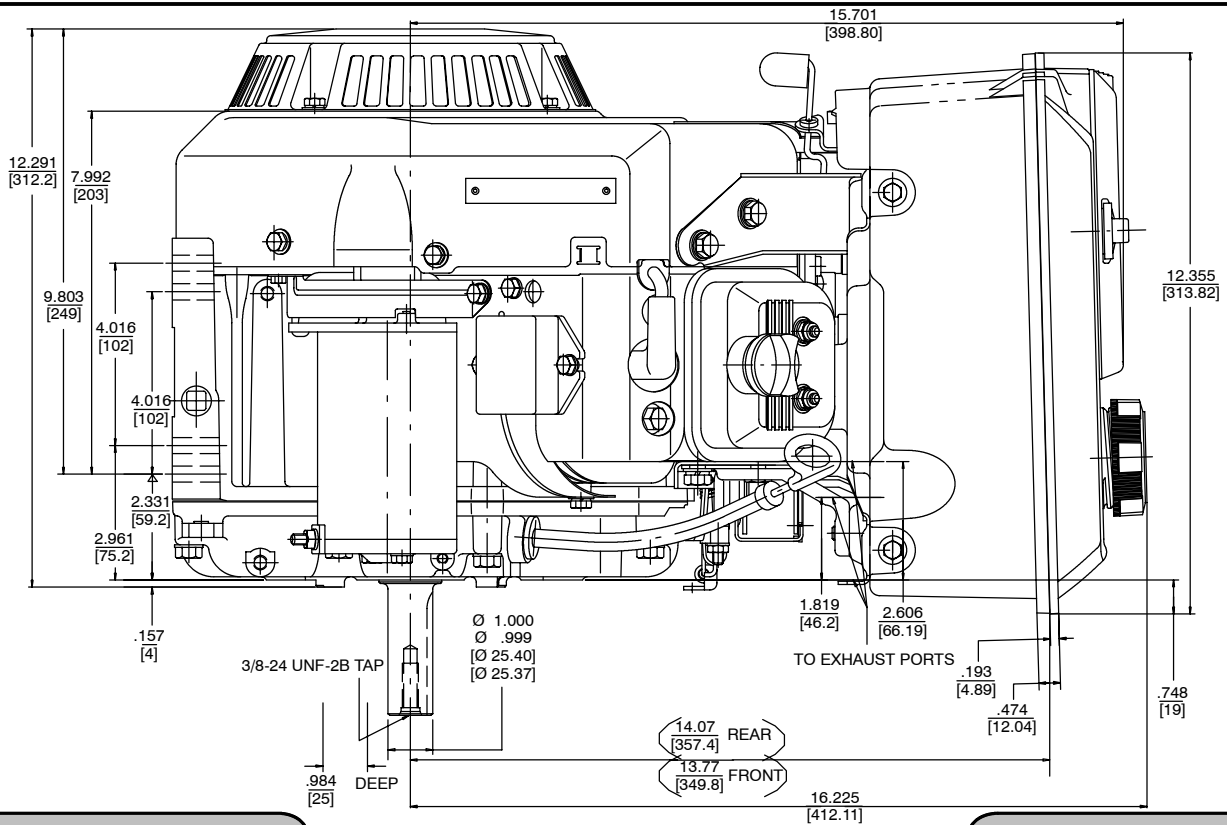

Oil Fill Side w/Fuel Tank

Dwg 3034000006



VANGUARD™

V-TWIN SERIES

Outline Drawings

18 HP 350400

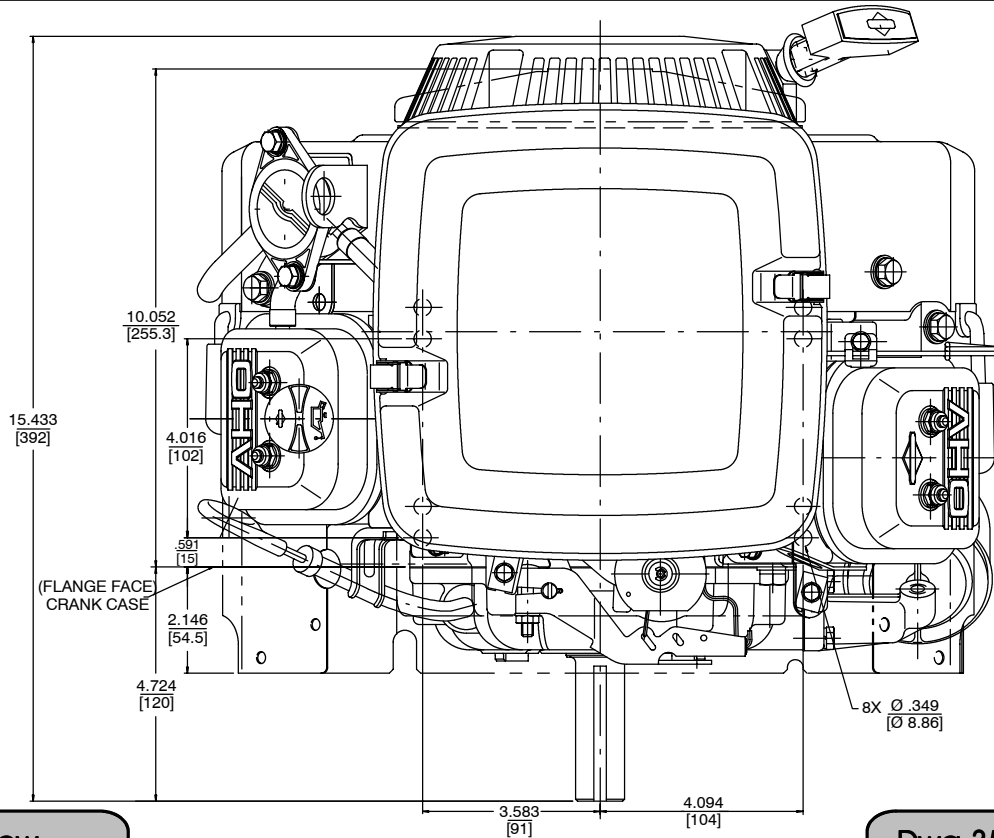

Top View

Dwg 3504000006

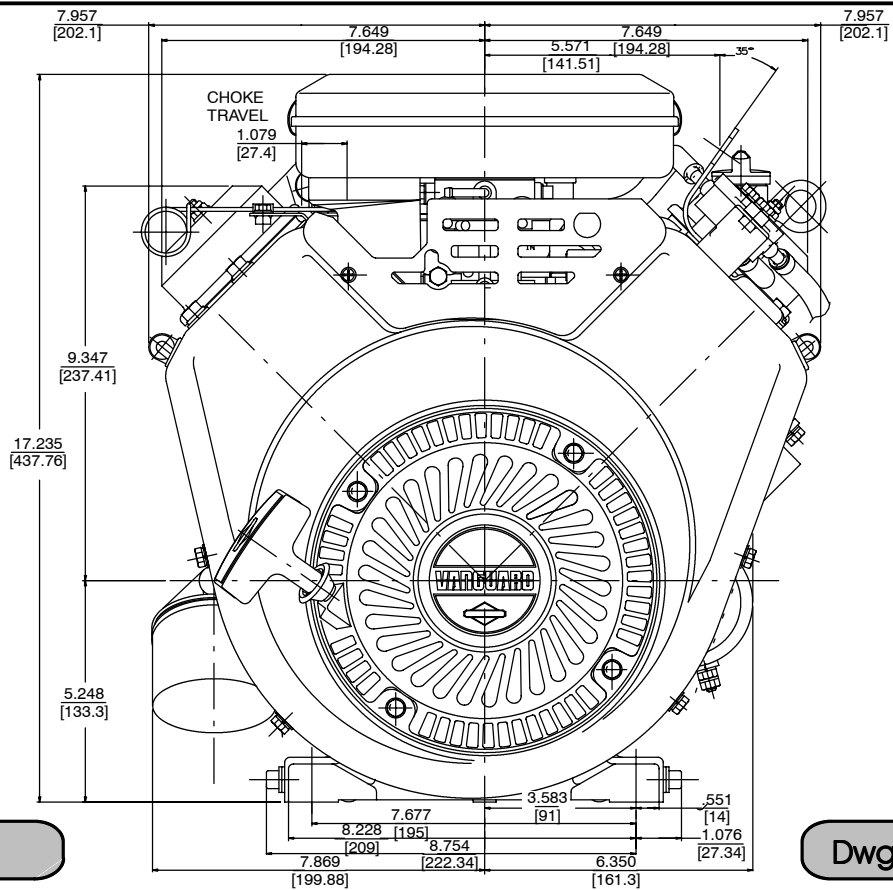

Front View

Dwg 3504000006

BRIGGS & STRATTON

VANGUARD™ V-TWIN SERIES

18 HP 350400

Outline Drawings

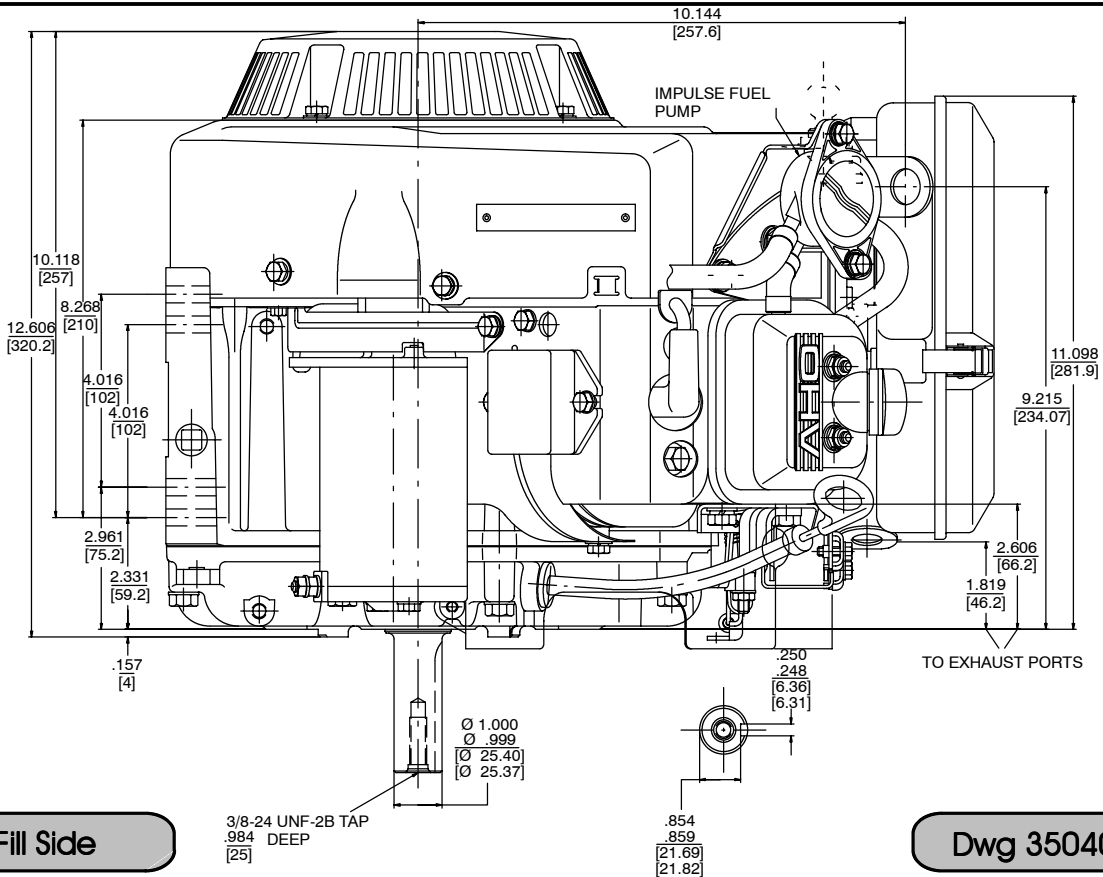
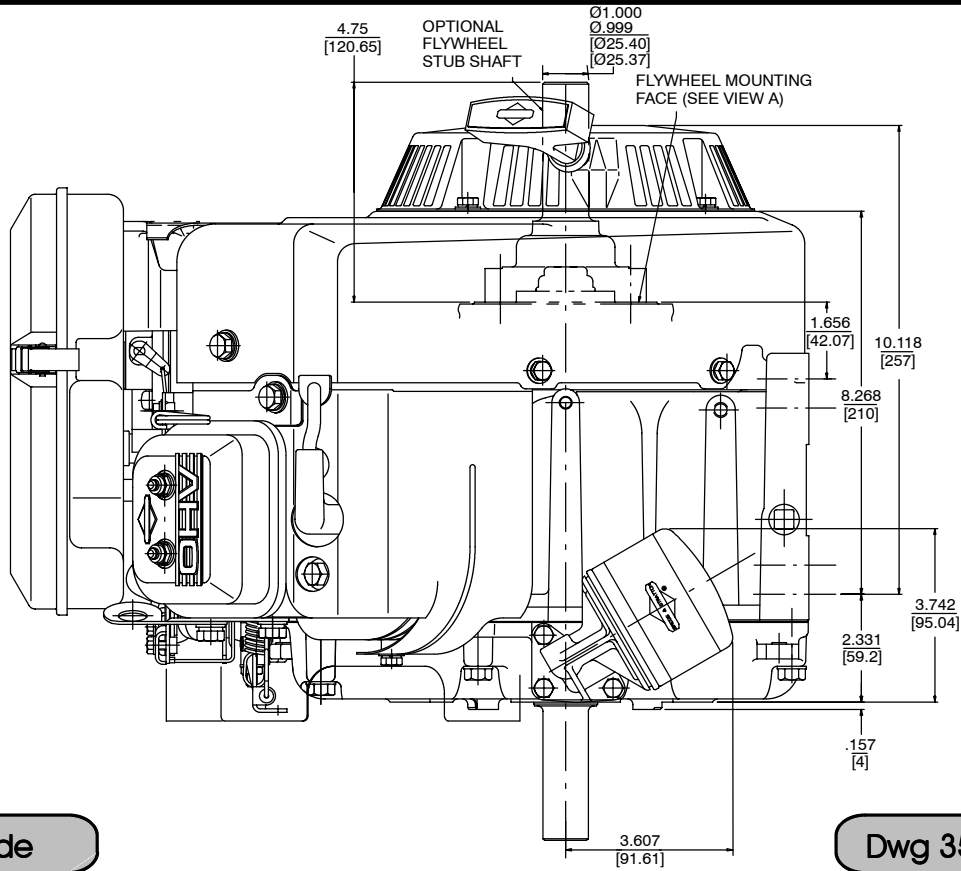



VANGUARD™

V-TWIN SERIES

Outline Drawings

18 HP 350400

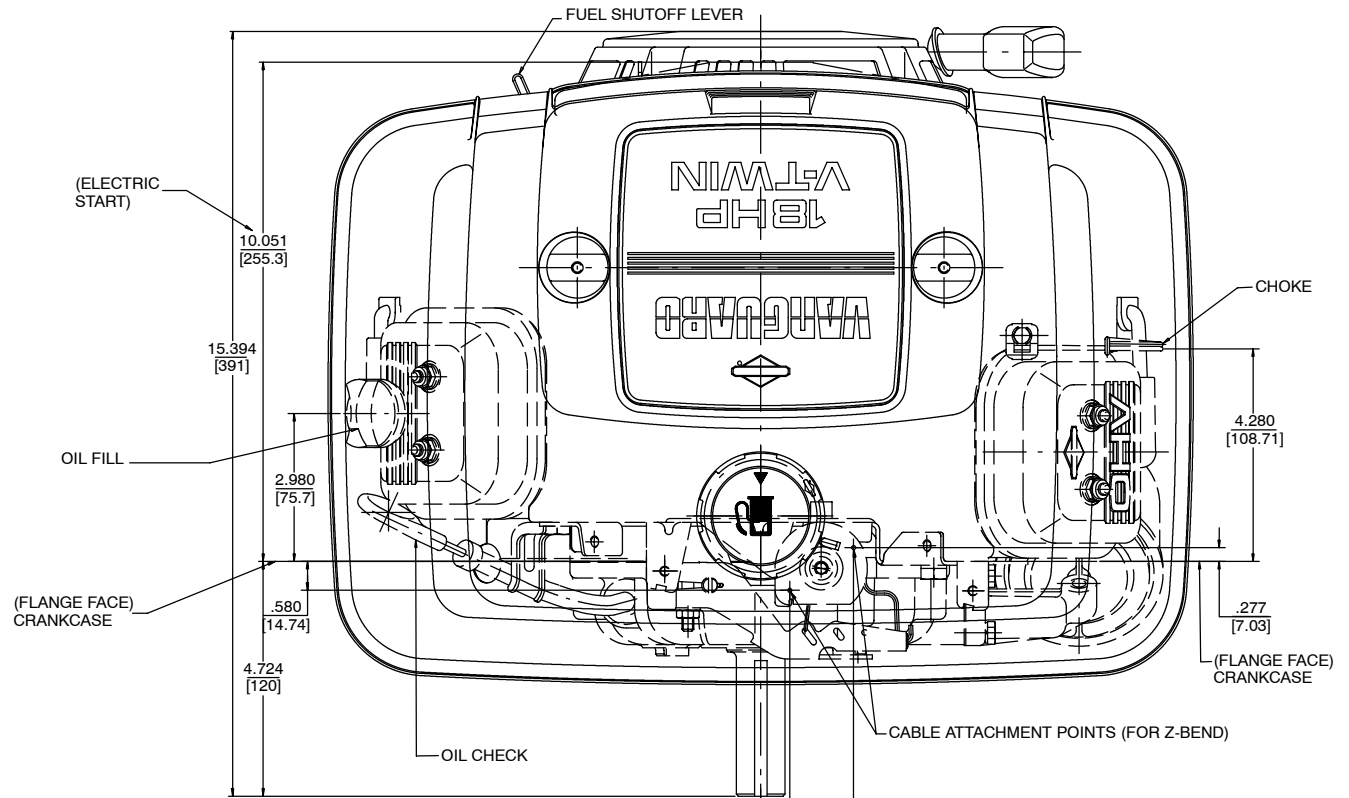

Top View w/Fuel Tank

Dwg 350400000016

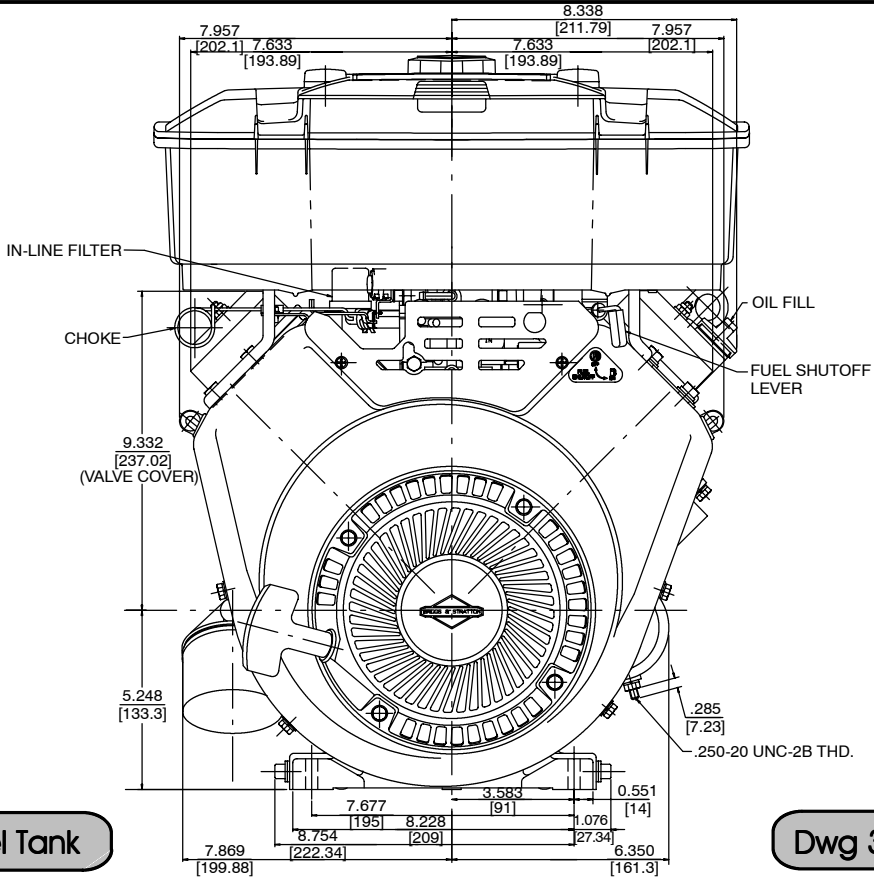

Front View w/Fuel Tank

Dwg 350400000016

Outline Drawings

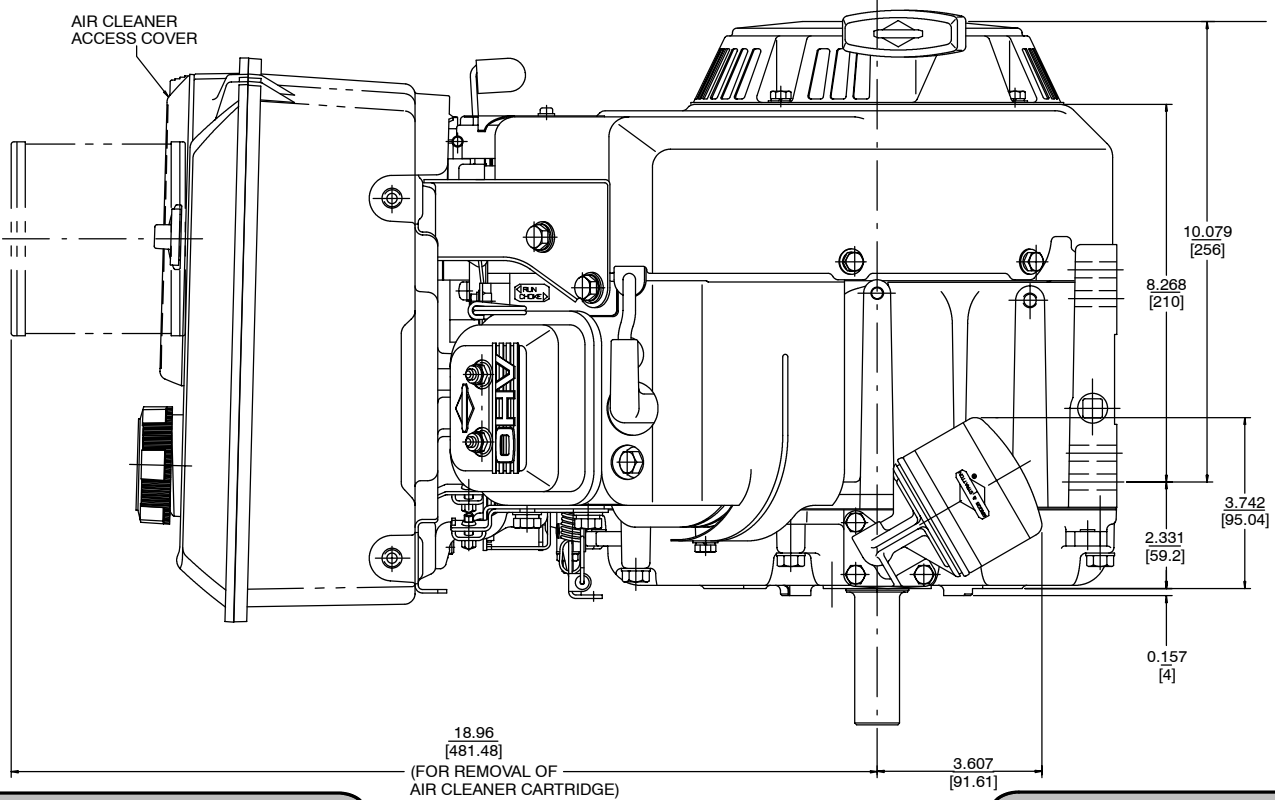

Oil Filter Side w/Fuel Tank

Dwg 35040000016

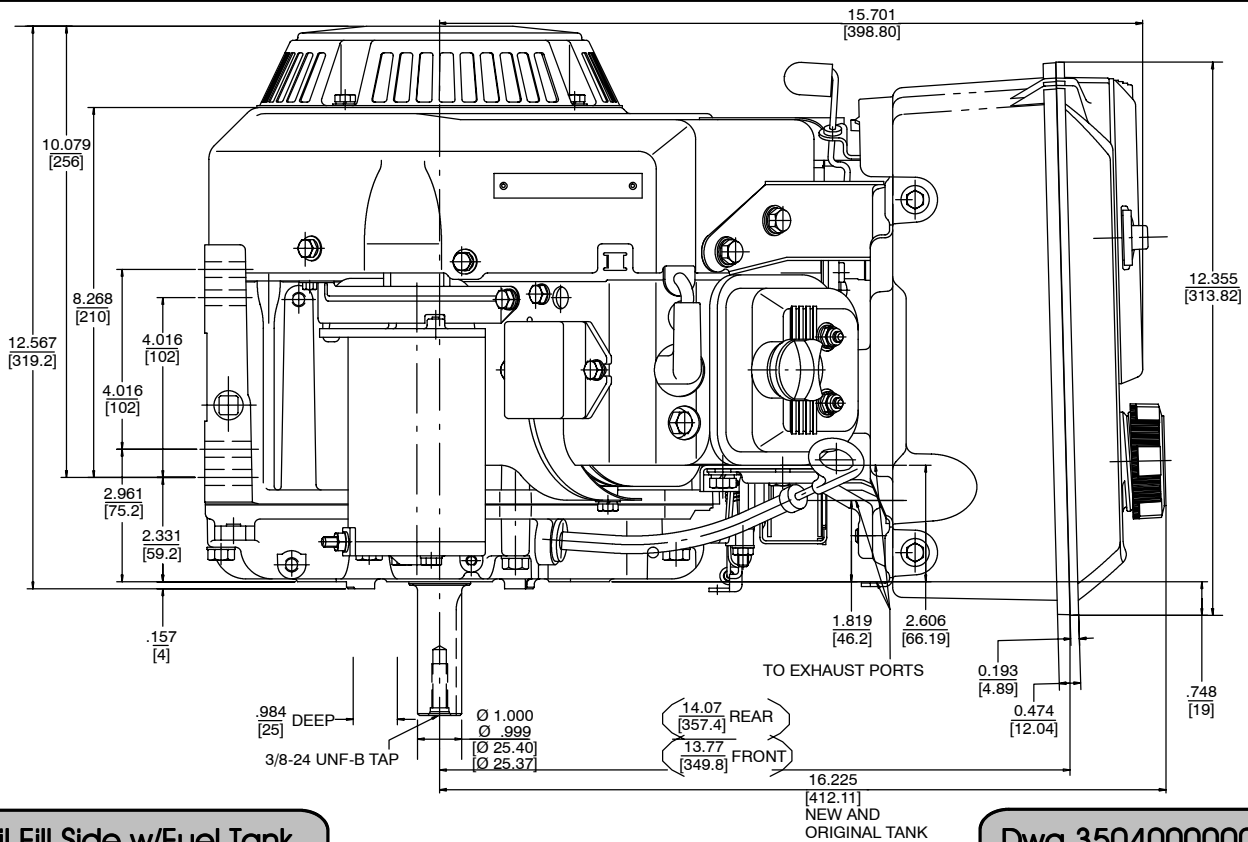

Oil Fill Side w/Fuel Tank

Dwg 35040000016



VANGUARD™ V-TWIN SERIES

16 HP 303400
18 HP 350400

Outline Drawings

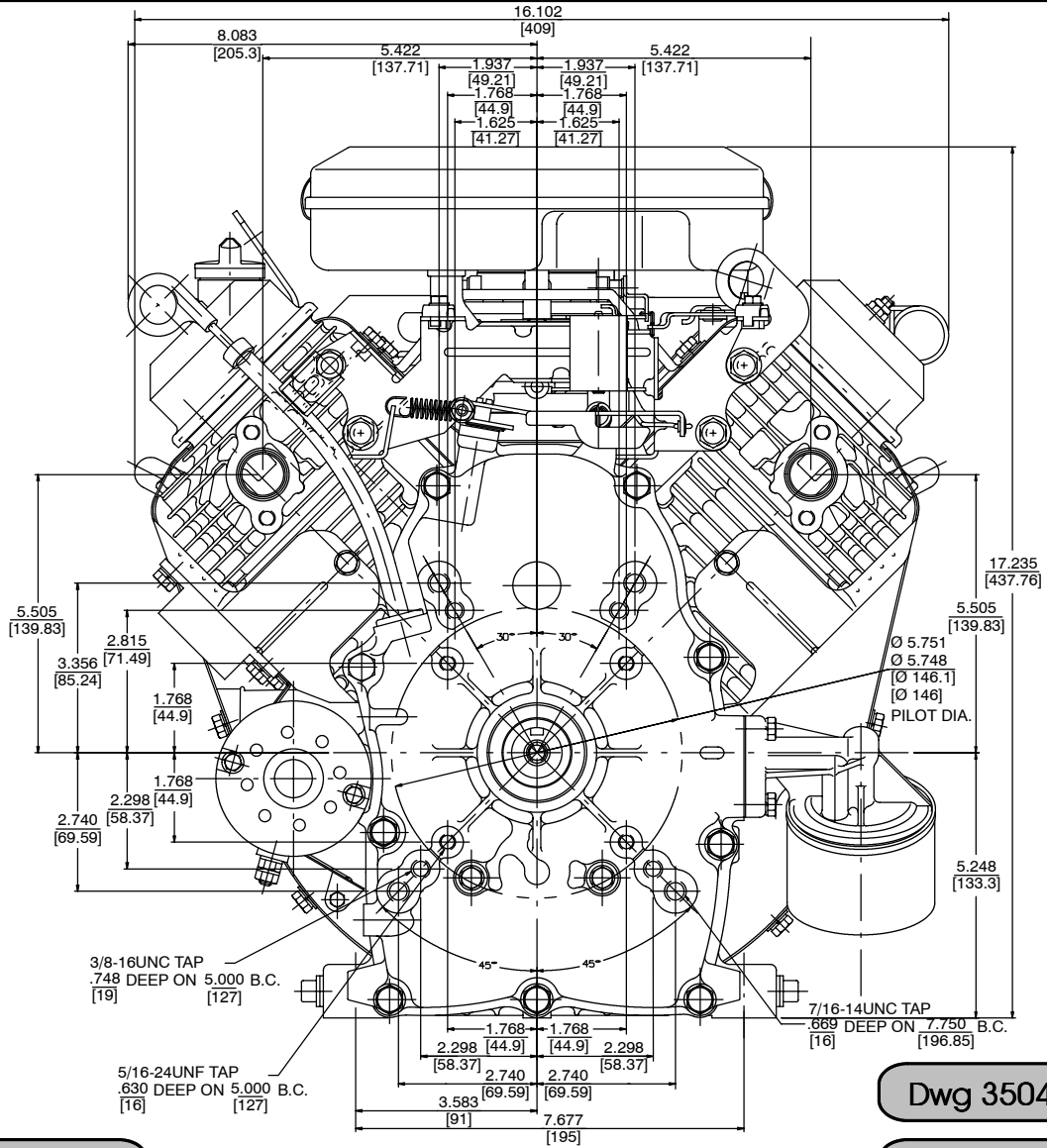

PTO Side View

Dwg 35040000006

Dwg 29040000006

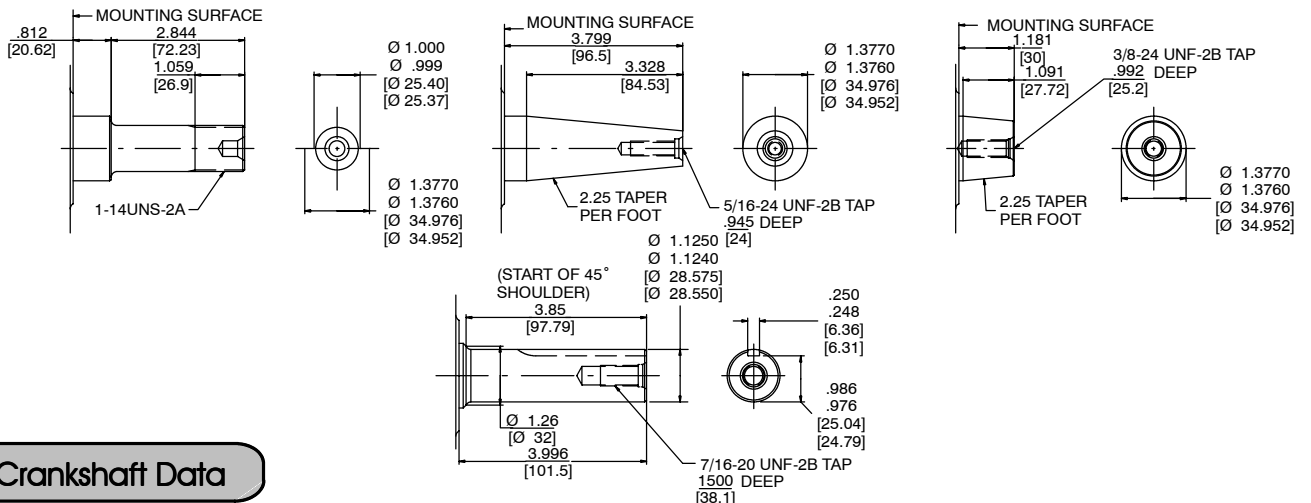

Crankshaft Data

Outline Drawings

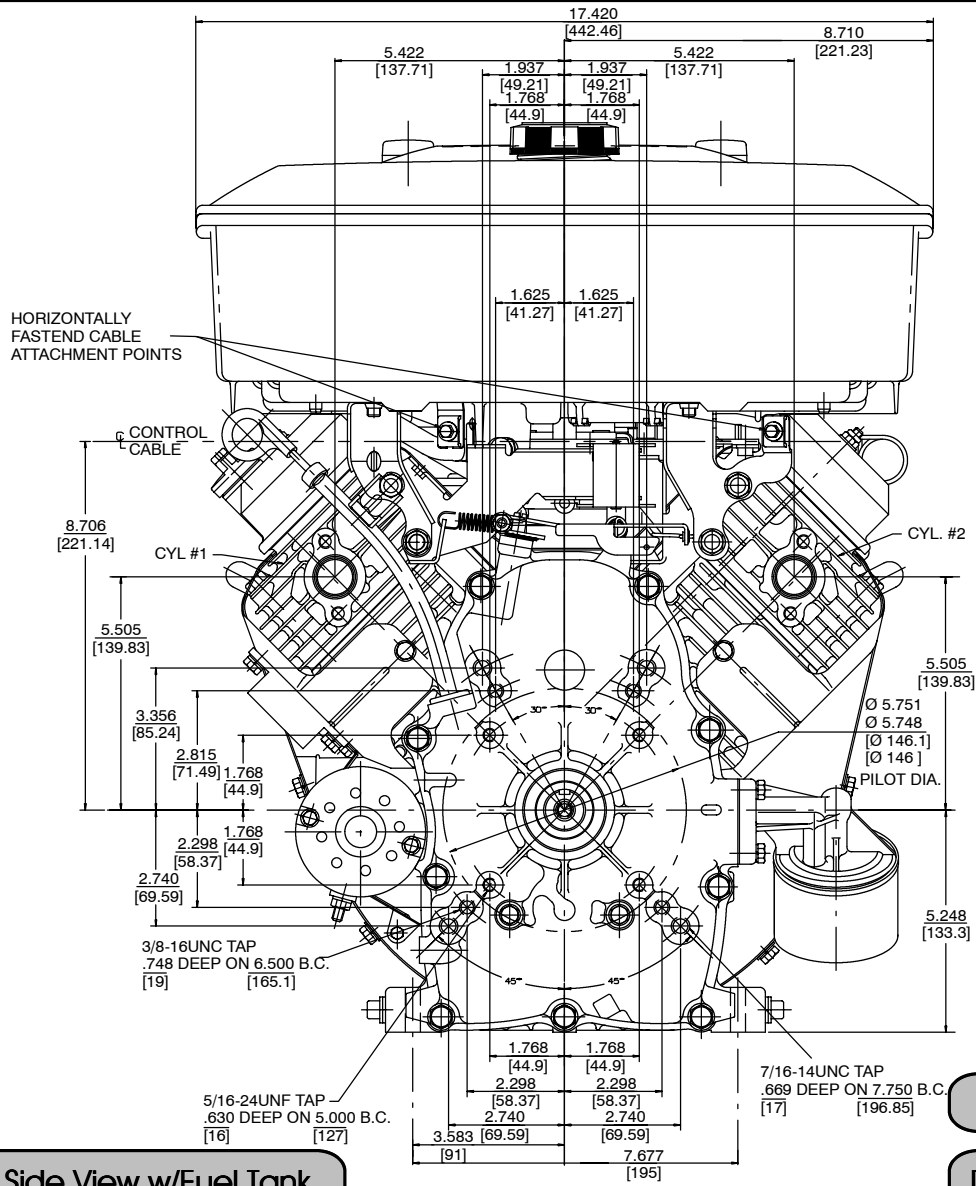

PTO Side View w/Fuel Tank

Dwg 30340000006

Dwg 350400000016

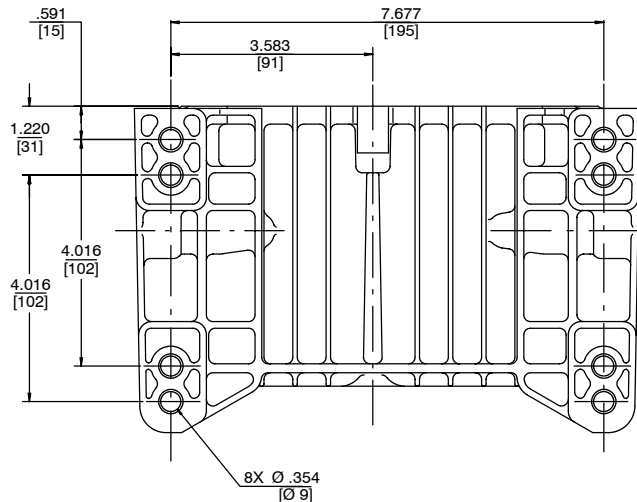

Footprint



VANGUARD™ V-TWIN SERIES

16 HP 303400

Performance Data

Power Curve

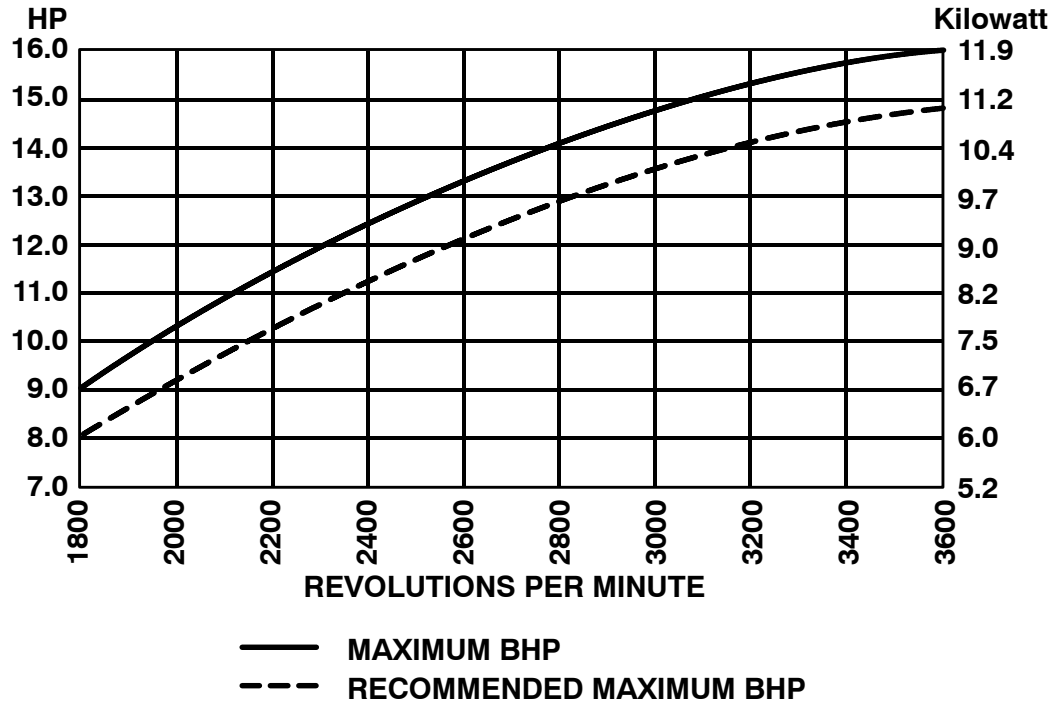

Torque Curve

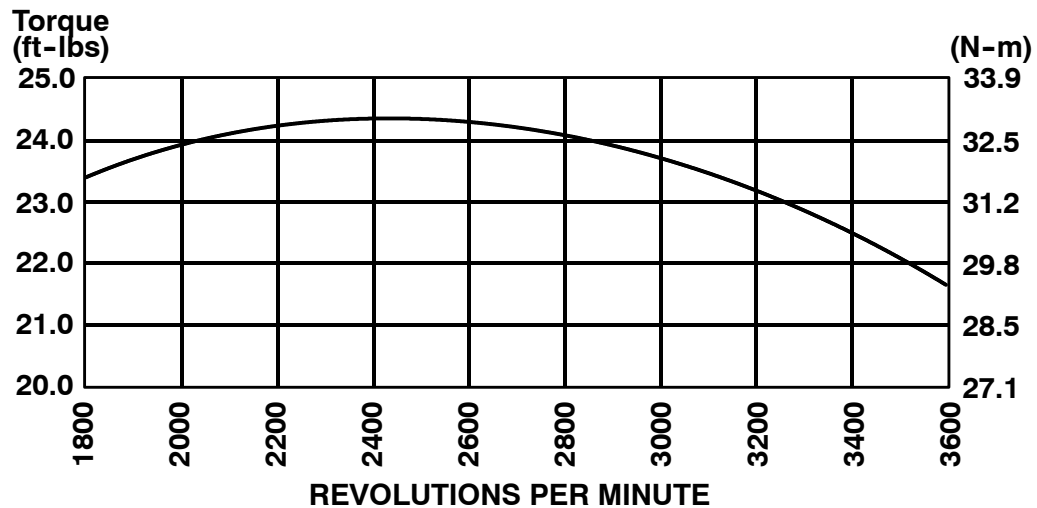



VANGUARD™ V-TWIN SERIES

18 HP 350400

Performance Data

Power Curve

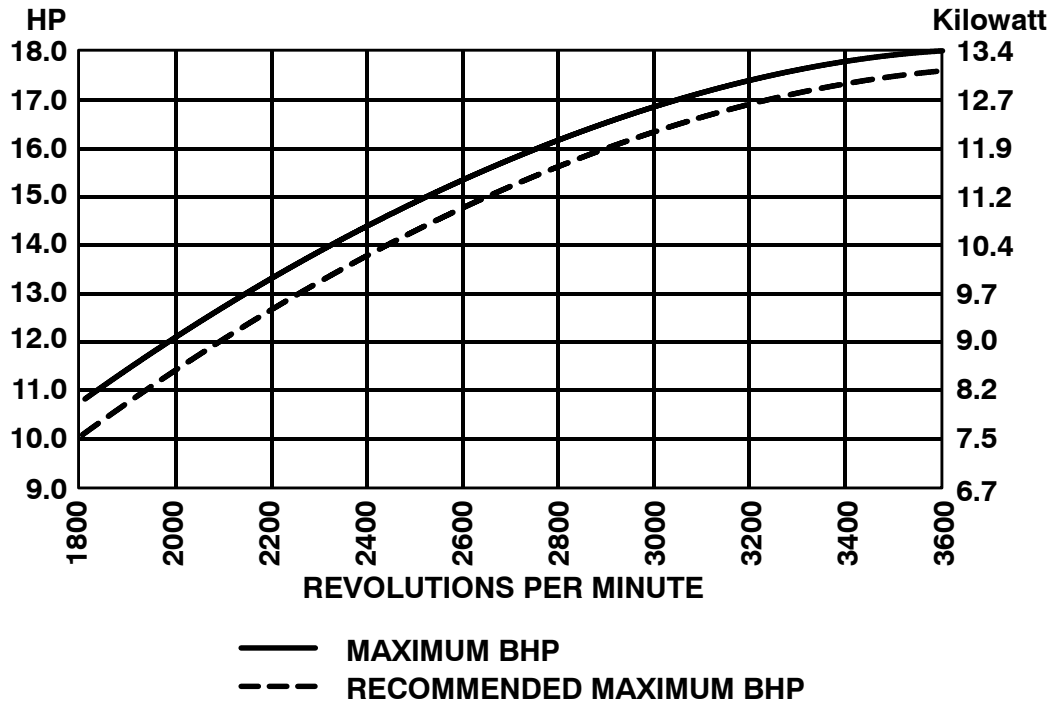

Torque Curve

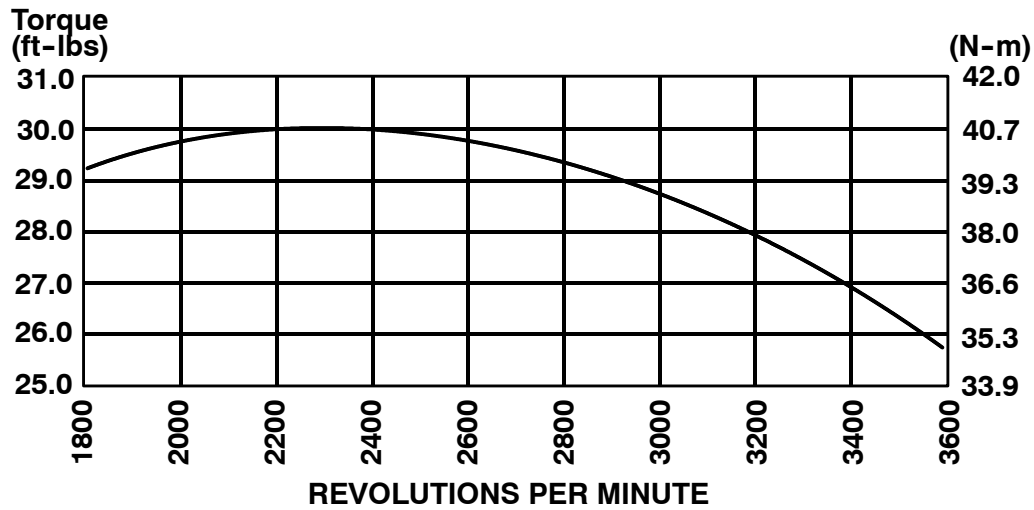



VANGUARD™ V-TWIN SERIES

16 HP 303400
18 HP 350400

Sound Performance

Sound Chart

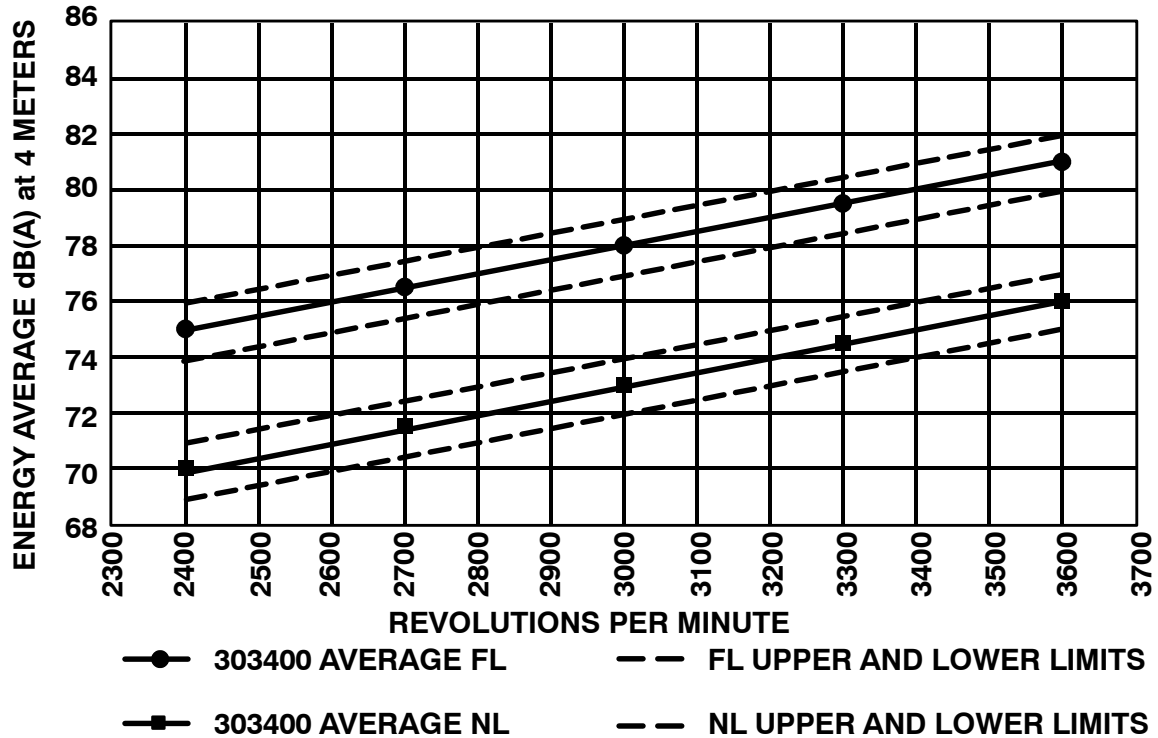

Sound Chart

